

## THERMAL LIQUID MASS FLOW CONTROLLER WITH FAST RESPONSE AND EASY RANGEABILITY

Lötters, Joost  
Bronkhorst High-Tech B.V.  
Nijverheidsstraat 1a, 7261 AK Ruurlo, The Netherlands  
E-mail: J.C.Lotters@Bronkhorst.com

### INTRODUCTION

Processes used in the semiconductor industry, in particular chemical vapour deposition (CVD), require new and continuously improving generations of liquid mass flow controllers (MFCs).

Typical precursor liquids applied in CVD are for instance  $\text{SiCl}_4$  for glass fiber production and CupraSelect™ (liquid copper) to replace aluminium as material for the electrical interconnection layer in electronic circuits. The flow range of these precursor liquids may vary between 10 g/h and 10 kg/h. Since this is a rather wide flow range, a suitable liquid MFC should have an easy rangeability.

In many semiconductor processes the precursor liquid has to be dosed intermittently. For instance, a certain mass flow of CupraSelect™ should be supplied to a process for 10 seconds and then be interrupted for 20 seconds. The total period time is 30 seconds, this period is repeated continuously. Other processes may require an even shorter period time. Therefore, the settling time of an MFC suitable for the semiconductor industry should preferably be less than 1 s. However, none of today's commercially available thermal liquid mass flow controllers meets this specification.

In this paper, a new thermal liquid MFC is presented that does meet the requirements as imposed by the semiconductor industry. First, the sensor structure and basic operating principle of the L20 liquid MFC are described, followed by a description of the occurring heat transfer, the necessary electronic circuitry, the resulting output voltage for a certain flow range and the conversion factor for different liquids with respect to isopropyl alcohol (IPA). Some measurement results will be presented and discussed, and finally some conclusions are drawn.

### SENSOR STRUCTURE AND BASIC OPERATING PRINCIPLE

The actual flow sensor in the L20 liquid mass flow controller consists of a straight stainless steel flow tube with a heater and a sensor resistor coil wound around it, as shown in figure 1a. The sensor resistance is used to measure and compensate for variations in the medium temperature. The heater resistance is heated to a certain constant temperature  $\Delta T$  over the medium temperature. The heater power necessary to keep  $\Delta T$  constant is a measure for the flow. This measurement principle is called *constant temperature anemometry* (CTA). Advantage of keeping  $\Delta T$  constant is that the sensor's response time is dramatically reduced.

L20 FLOW SENSOR      Flow Tube and Resistor Coils

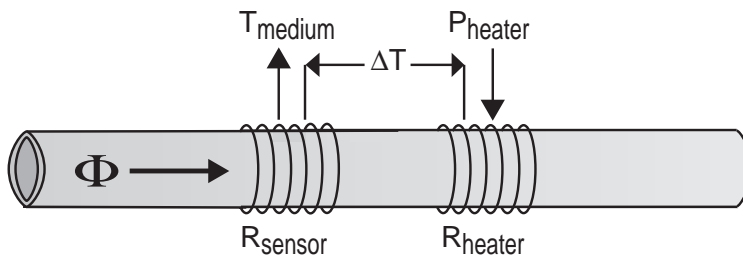

(a)



(b)

Figure 1. The (a) actual sensor and (b) final appearance of the L20 liquid mass flow controller

The L20 liquid mass flow sensor has the following advantages:

- The flow sensor comprises a short straight stainless steel flow tube, implying a small sized sensor, a low pressure drop, a small dead volume and no pollution due to residues left behind in a parallel channel.
- The measurable flow range can easily be adjusted by changing the flowtube, so a wide flow range from very low through very high flows can be covered with the same instrument.
- The sensitive elements are placed outside the flow tube, so all wetted parts are stainless steel.
- The temperature difference  $\Delta T$  between the heater and sensor resistance is kept constant (CTA: Constant Temperature Anemometry), which ensures a very fast response to changes in the flow rate.
- The temperature difference is low,  $\Delta T \leq 5 \text{ }^\circ\text{C}$ , which prevents the liquid from boiling.
- The CTA control loop is implemented in such a way that intrinsic temperature compensation is provided.
- The sensor's behaviour can be theoretically predicted, so the need for actual calibration is reduced.

## HEAT TRANSFER

At the end of the 19<sup>th</sup> century, Graetz derived an equation with which the heat transfer due to *forced convection* by means of a laminar flow through a cylindrical flow tube with an isothermal wall can be calculated [1, 2, 3, 4]:

$$Nu = C \cdot Gz^{0.333} \quad Gz > 10 \quad Re < 2300 \quad (1)$$

with  $Nu$  [-] the Nusselt number, representing the dimensionless heat transfer coefficient,  $C$  [-] a proportional constant and  $Gz$  [-] the Graetz number, which can be expressed as

$$Gz = Re \cdot Pr \cdot \frac{D}{L} \quad (2)$$

with  $Re$  [-] the Reynolds number, in which the mass flow is represented,  $Pr$  [-] the Prandtl number,  $D$  [m] the diameter of the flow tube and  $L$  [m] the length of the flow tube.

In the L20 liquid mass flow sensor, the heater resistance  $R_{heater}$  [ $\Omega$ ] is heated to a certain constant temperature  $\Delta T$  [ $^\circ\text{C}$ ] over the medium temperature. The heater power  $P_{heater}$  [W] necessary to keep  $\Delta T$  constant is dependent on the mass flow and can be calculated with

$$P_{heater} = K \cdot Nu \cdot \Delta T \quad (3)$$

with  $K$  [ $\text{W}/^\circ\text{C}$ ] a constant in which among others the heater and flow tube dimensions and liquid properties  $c_p$  [ $\text{J}/(\text{kg}\cdot\text{K})$ ],  $\rho$  [ $\text{kg}/\text{m}^3$ ],  $\lambda$  [ $\text{W}/(\text{m}\cdot\text{K})$ ] and  $\mu$  [ $\text{Pa}\cdot\text{s}$ ] are taken into account. Using (3), the behaviour of the flow sensor for different liquid types can be predicted.

## ELECTRONIC CIRCUITRY

A schematic diagram of the L20 mass flow sensor and its excitation/read-out electronics are shown in figure 2. The electronic circuitry can be divided into two main functional blocks. Namely, the *control loop*, which regulates the heater power as a function of the occurring flow in such a way that  $\Delta T$  is kept constant, and the *signal conditioning* circuitry, which makes sure that the output voltage shows a linear relation with the flow.

Most important part of the electronic circuitry is the control loop, which ensures that the heater is provided with extra current to compensate for the heat loss due to forced convection, as described in the previous section. The control loop comprises the two sensing resistances in a Wheatstone bridge configuration and a controller for an optimum response.

The signal conditioning block converts the occurring non-linear heater voltage  $V_{heater}$  [V] into an output voltage  $V_{out}$  [V] which varies linearly with the flow in the range 0 – 5 V. To reach this goal, the signal conditioning circuitry comprises an offset nulling, linearisation and amplification stage.

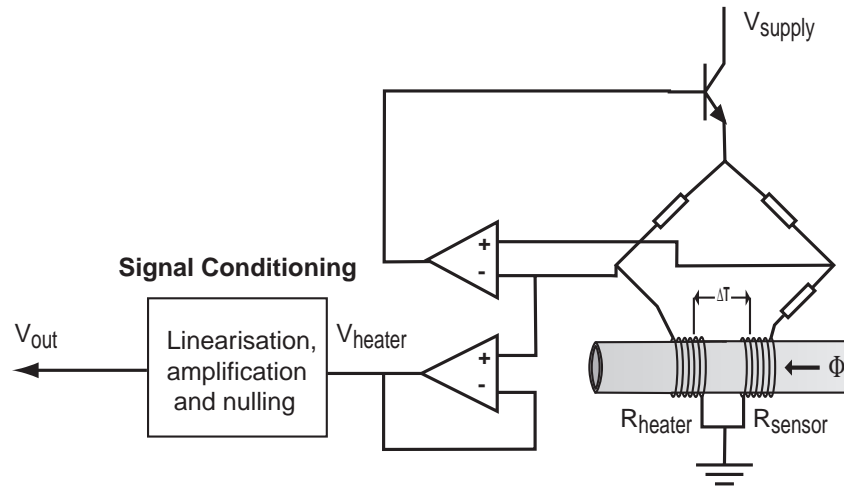

Figure 2. Schematic diagram of the L20 liquid mass flow sensor and its electronic circuit

### OUTPUT VOLTAGE

The heater power has to be converted into a useful linear output signal with the aid of the electronic circuitry. In the circuit, the heater power is first converted into a heater voltage via

$$V_{heater} = \sqrt{P_{heater} \cdot R_{heater}} \quad (4)$$

Then, the heater voltage is linearised and the offset voltage due to  $P_{offset}$  is eliminated. The resulting linear output voltage  $V_{out}$  [V] can be calculated with

$$V_{out} = K \cdot \Phi_m \quad (5)$$

with  $K$  [V·s/kg] a constant in which among others the heater dimensions, the gain factor of the electronic circuitry and the liquid properties  $\lambda$  [W/(m·K)] the heat conduction,  $c_p$  [J/(kg·K)] the specific heat and  $\mu$  [Pa·s] the dynamic viscosity are taken into account, and  $\Phi_m$  [kg/s] the mass flow of the liquid.

### CONVERSION FACTOR

An L20 liquid mass flow controller can be applied for most liquid types. Since it is rather impractical to perform an actual calibration for each liquid, it would be easy if all calibrations could be performed with a reference liquid, such as for instance isopropyl alcohol (IPA). Therefore, it is necessary to know the relation between IPA and the liquid under calibration. This relation is given by the *conversion factor* (CF). Using equation (5), the conversion factor can be calculated with

$$CF = \frac{V_{out,IPA} \Big|_{\Phi_m=C}}{V_{out,LIQUID} \Big|_{\Phi_m=C}} = \frac{K_{IPA}}{K_{LIQUID}} \quad (6)$$

In table 1, a list of calculated conversion factors of an L20 MFC suited for 1000 g/h IPA for some other liquids is presented.

IPA	1.00	SiCl <sub>4</sub>	5.56
Water	0.14	TiCl <sub>4</sub>	5.80
Methanol	0.62	TEOS	1.30
Ethanol	1.00	CupraSelect™	4.12
Propanol	1.31	HMDS	1.26

\*Subject to change without notice

For example, the conversion factor of methanol with respect to IPA is equal to 0.62 at  $T = 20\text{ }^{\circ}\text{C}$  and  $p = 1$  bar. So, the equivalent of 1000 g/h IPA =  $1000 \times 0.62 = 620$  g/h methanol. Subsequently, the equivalent of 1000 g/h methanol =  $1000 / 0.62 = 1613$  g/h IPA.

## CONTROL LOOP

A block diagram of the control loop of the L20 liquid mass flow controller is shown in figure 3. The control loop consists of the mass flow sensor and its corresponding electronic circuitry, a proportional control valve and a control unit.

The desired flow can be adjusted by applying the corresponding set point to the control loop. A certain set point corresponds to a certain value of the flow. For instance, in case of an L20 adjusted for 1000 g/h IPA, a set point of 40 % corresponds to a flow of 400 g/h IPA. When the set point is set to a value, the control loop makes sure that the desired value is reached. Moreover, the control loop takes care that the desired value is reached as quickly as possible with a smooth response.

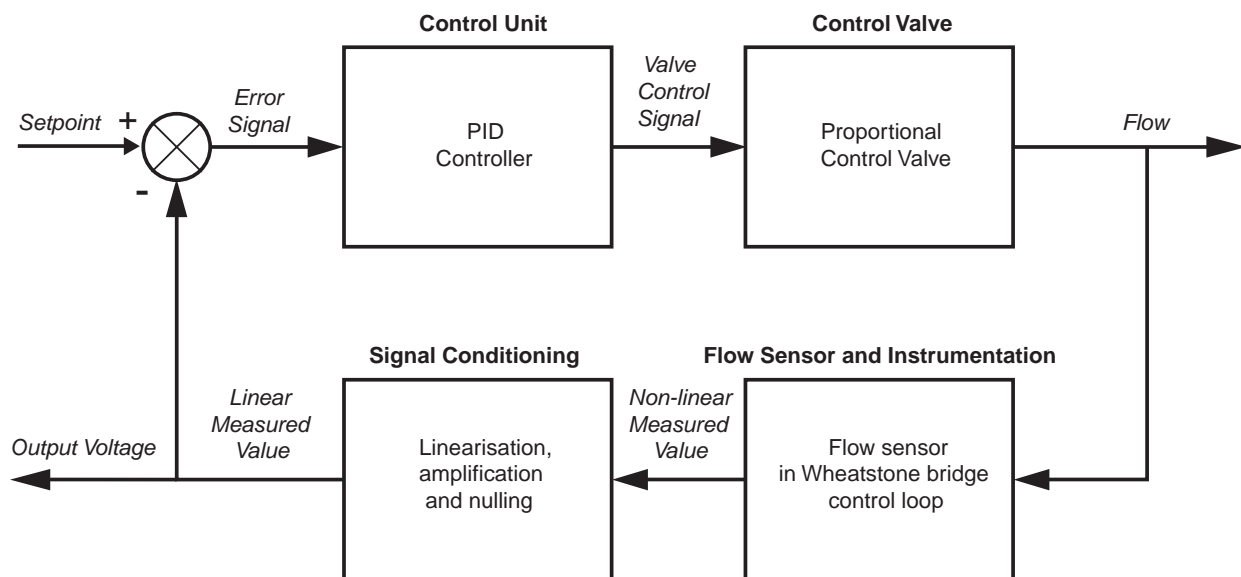

Figure 3. Block diagram of the control loop of the L20 liquid mass flow controller

## EXPERIMENTAL

Several L20 liquid mass flow controllers have been built for different ranges, varying between 200 and 2000 g/h. The instruments have been thoroughly tested for different liquids at all important features, such as linearity, resolution, inaccuracy, response time, repeatability, stability, (temperature) drift, pressure drop and dependency, power consumption and EMC compatibility.

The calculated conversion factors have been experimentally verified by performing measurements on an instrument suited for 1000 g/h IPA. First, the instrument was calibrated in such a way that a mass flow from 0 up to 1000 g/h IPA resulted in a linearly varying output voltage from 0 up to 5 V with a maximum inaccuracy of  $\pm 1\%$  F.S. The settings of the instrument were not adjusted during the experiment. Then, several other liquids, like water, methanol and silicon tetrachloride were applied to the instrument and the output voltage was measured with a digital multimeter.

The same MFC was used for the measurements of the dynamic behaviour. The following three stepwise variations in set point were performed:

- 0 %  $\Rightarrow$  100 %  $\Rightarrow$  0 %
- 20 %  $\Rightarrow$  80 %  $\Rightarrow$  20 %
- 20 %  $\Rightarrow$  40 %  $\Rightarrow$  60 %  $\Rightarrow$  80 %  $\Rightarrow$  100 %

The resulting response time of the MFC was measured by a digital oscilloscope.

## RESULTS AND DISCUSSION

The measurement results of the conversion factor check are displayed in figure 4, the measurement results of the response time tests can be found in figure 5.

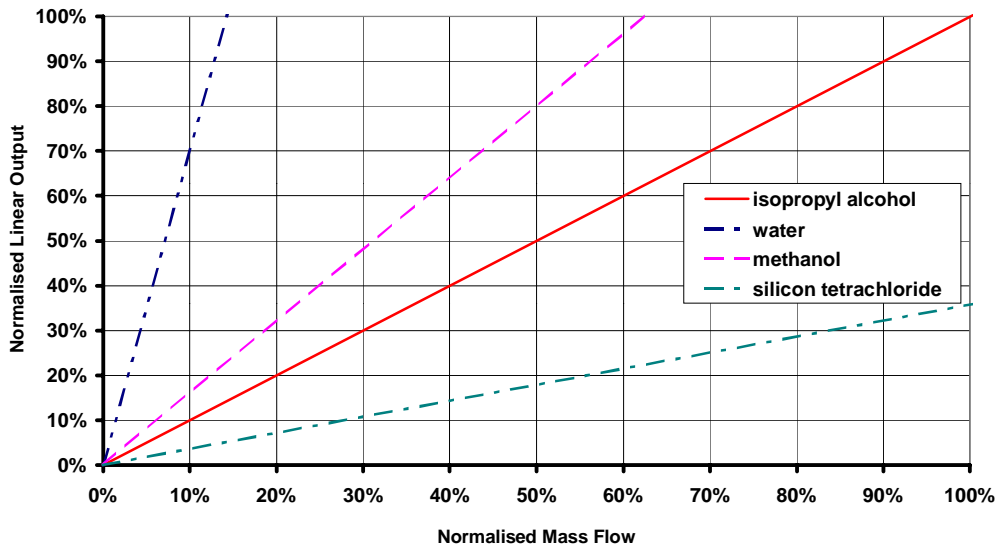

Figure 4. Measurement results obtained with an L20 liquid MFC adjusted for IPA:  $1000 \text{ g/h} \equiv 5 \text{ V}$ ;

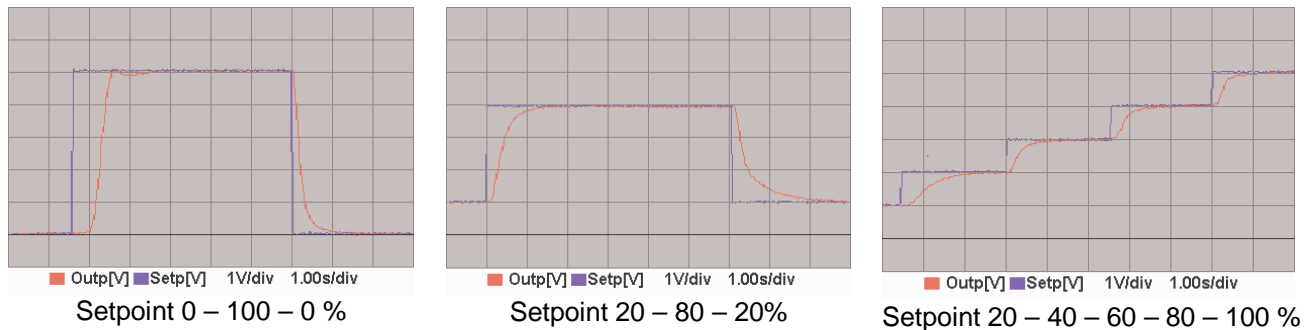

Figure 5. Measured response times of an L20 liquid MFC adjusted for IPA:  $1000 \text{ g/h} \equiv 5 \text{ V}$ ;  
The X-axis shows the time [s] with  $1 \text{ s} / \text{div.}$ , the Y-axis displays the output voltage [V] with  $1 \text{ V} / \text{div.}$

The measured curves for  $\text{H}_2\text{O}$ ,  $\text{CH}_3\text{OH}$  and  $\text{SiCl}_4$  with respect to IPA, as displayed in figure 4, correspond well with the theoretically expected values as given in table 1. As can be seen in figure 4, there is a good correspondence between calculated and measured values. However, some deviations between theory and measurements occur. They can be explained as follows:

- not all boundary conditions for equation (1) were fully fulfilled, so the heat transfer had a somewhat different behaviour than expected.
- practical dimensions, temperatures and pressures differed from the values used in the calculations.

The measured response times, as shown in figure 5, are all within the value of  $\tau_{98\%} = 2 \text{ s}$ . Some redesign has to be performed in order to decrease the response time under all conditions down to the specified  $\tau_{98\%} \leq 1 \text{ s}$ .

## CONCLUSIONS

Several L20 liquid mass flow controllers, as shown in figure 1b, have been built for ranges varying between  $200 \text{ g/h}$  and  $2000 \text{ g/h}$ . It has been shown that the L20 is capable of controlling different liquids within this range, including IPA, water, methanol and  $\text{SiCl}_4$ , with a settling time less than  $\tau_{98\%} = 2 \text{ s}$ . Moreover, the measurement results show a good correspondence with the theoretically expected values, which implies that the behaviour of the instrument for other liquids than the ones used here can be well-predicted.

## REFERENCES

- [1] F.P. Incropera, D.P. DeWitt, *Fundamentals of Heat and Mass Transfer*, John Wiley & Sons, 1996
- [2] A. Bejan, *Heat Transfer*, John Wiley & Sons, 1993
- [3] J.J. Feijen, *Inleiding tot de warmtetechniek*, Van Nijgh & Ditmar, Rijswijk, The Netherlands, 1987, *in Dutch*
- [4] J.M. Smith, E. Stammers, L.P.B.M. Janssen, *Fysische Transport Verschijnselen I*, Delft University Press, Delft, The Netherlands, 1981, *in Dutch*

## ACKNOWLEDGMENTS

The author would like to thank D. Thoenes, G.J. de Bruin and W.C.M. Gorissen (all University of Twente) for their valuable contributions to the theoretical modelling of the sensor's heat transfer. Furthermore, the author would like to thank R. Besseling and J.R. Willemsen of Bronkhorst High-Tech for performing the measurements.