



Badger Meter Europa GmbH

Flow meter type DP

INSTALLATION MANUAL

November 2007

1. The differential pressure producer is calculated for definite pipe lines and operating data. Therefore the data of the pipe lines must be controlled before installation and the measuring points must be compared.
2. The installation point of the differential pressure producer has to be chosen in that way that there is sufficient length of cylindrical pipe before and behind it and that there are no disturbances in it. The inlet and outlet ranges depend on the kind of the installation disturbances and on the relation to the diameter (see list).
3. The inside wall of the tube range must be clean 10 D and 4 D behind the head meter, free of form scars, deposits or incrustations.
4. The leading side (sharp edge of the orifice plate) is marked with "+". The direction of the arrow on the differential pressure producer shows the direction of the flow.
5. The installation of the differential pressure producer between flange with even packing strip has to be done with two bonds which are adapted to pressure, temperature and media. Neither bonds nor differential pressure producer should extend into the pipe line. Therefore the inner diameter of the differential pressure producer fitting rings should be chosen somewhat larger according to DIN 19205.
6. Differential pressure producers with even packing strip are centred by the flange screws. On horizontal assembly the lower flange screws have to be mounted first, then the orifice plate and the bonds are inserted from above. The last screws can be mounted and lightly tightened. Install orifice plate centric (may be measured from the outer flange diameter). Finally tighten the screw bolts.
7. The differential pressure drain spouts have the following position:
Angular position according to DIN 19205:

a) Gas measuring:

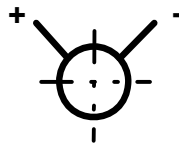

- in an upper angle:
Condensate runs off into the measuring pipe

b) Liquid measuring:

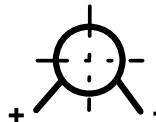

- in an angle below:
the pipe remains filled with
without entering of air when
pipe line runs

c) Steam measuring:

- the two differential pressure drain spouts must be horizontal and on same level. The condensation vessels hold the condenser water in both measuring pipes on the same level.

c.1) in a horizontal pipe line

c.2) in a vertical pipe line

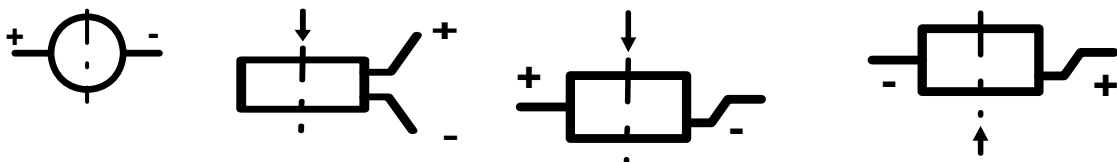

8. Shutoff valves are mounted to the nozzles of the differential pressure producer or to the condensation valve.

9. The measuring circuits have to be stringed in descent.

- With steam and liquids a pressure release has to be provided at the highest point.
- With gas a drainage has to be provided at the lowest point.

The differential pressure circuits (+) respectively (-) must be led into the corresponding inlets (screws of valve block). The transmitter is directly screwed on the valve block with included mounting material.

10. Installation of DP-flow element may only be done by trained staff. Maintenance and starting-up may only be carried out by trained specialists.

11. The differential pressure transducer is produced and designed according to the given operating data resp. layout data. You can find these data in the transmitted documentation. The values must not exceed the given data in the documentation.

12. Generally you can find the following identification on the instrument:

- Tag-number
- Pipe inner diameter „D“
- Throttle opening diameter: „d“
- Nominal pressure of DP-flow element: “PN“
- Material of DP-flow element / Material of throttle opening
- Flow direction by means of an arrow

Additionally customer relevant data and heat-number for material tracing and tag-numbers according to “DGLR” may be added.

13. Starting apparatus

All valves have to be closed.

a. Gas- respectively Liquid- Measuring

1. Opening of the orifice plate shutoff valves
2. Opening of the valves 1 and 3 of the valve block. Pay attention that the differential pressure circuits are ventilated (liquid measuring) respectively drained (gas measuring)
3. Control of Zero point
 - Shut the valves 1 and 3.
 - Open valve 2.
 - Indication respectively electric signal has to show „zero“.

b. Steam measuring

1. Opening of the orifice plate shutoff valve
2. Opening of the valve 4 and 5 of the block (blow out).
Wait until condensate (liquid) has been produced.
Close shut valves 4 and 5.
3. Continue as indicated under point 2. (s.a.)



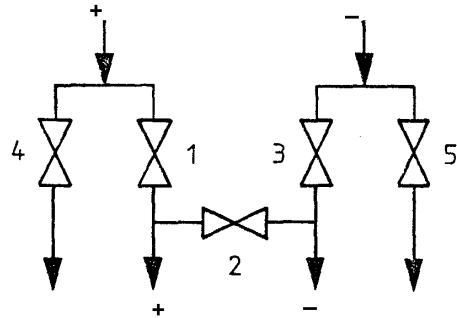
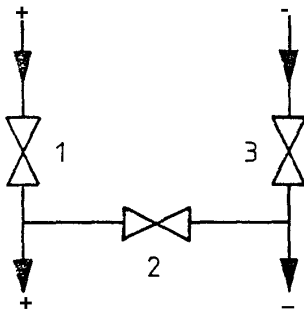
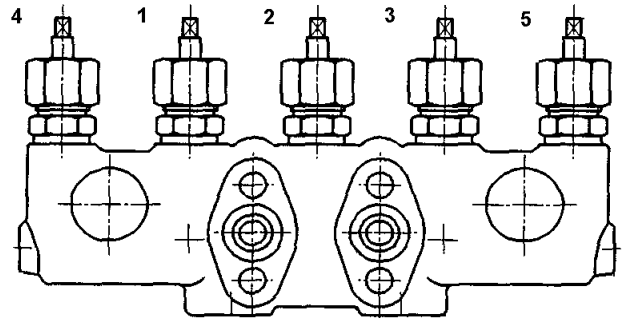
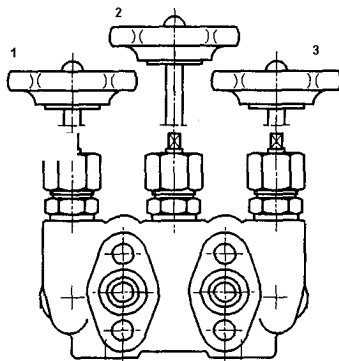

14. Required maintenance works must be carried out with consideration of corresponding field and/or trained staff. Security advises of these departments and the staff have definitely taken into account (checking pressure/temperature / Valves have to be closed).
15. Differential pressure transducers do not require maintenance works if used in a workmanlike way. When having standard revisions of the material it is recommended to examine the differential pressure transducer intensively to ensure the functionality (material/ edge sharpness, traces of tool wear).
16. To determine the required up- and downstream paths for different differential pressure transducers considering different disturbances and opening ratios, refer to ISO 5167.



Hotline

Tel. +49-7025-9208-0 or -31
Fax +49-7025-9208-15



Badger Meter Europa GmbH

Subsidiary of Badger Meter, Inc., USA

Nürtinger Strasse 76
72639 Neuffen (Germany)
E-mail: badger@badgermeter.de
www.badgermeter.de